

APPLICATIONS

Feed pumps for cargo boilers on diesel ships

GENERAL CHARACTERISTICS

Item	Model	GHQ 100-2
Rotation		Clockwise when viewed from the driver
Suction bore	(mm)	100
Discharge bore	(mm)	100
Stuffing box seal		Gland packing or Mechanical seal
Max.output	(kW)	110
weight:FCD	(kg)	300
Water filled in casing	(kg)	10

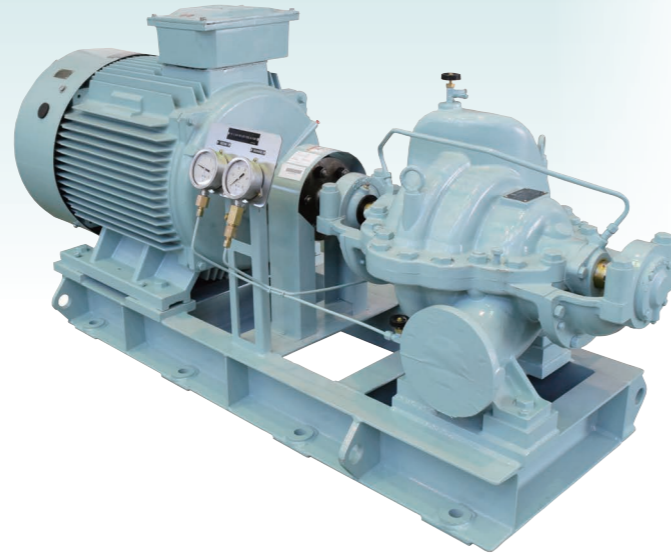

PERFORMANCE CHART

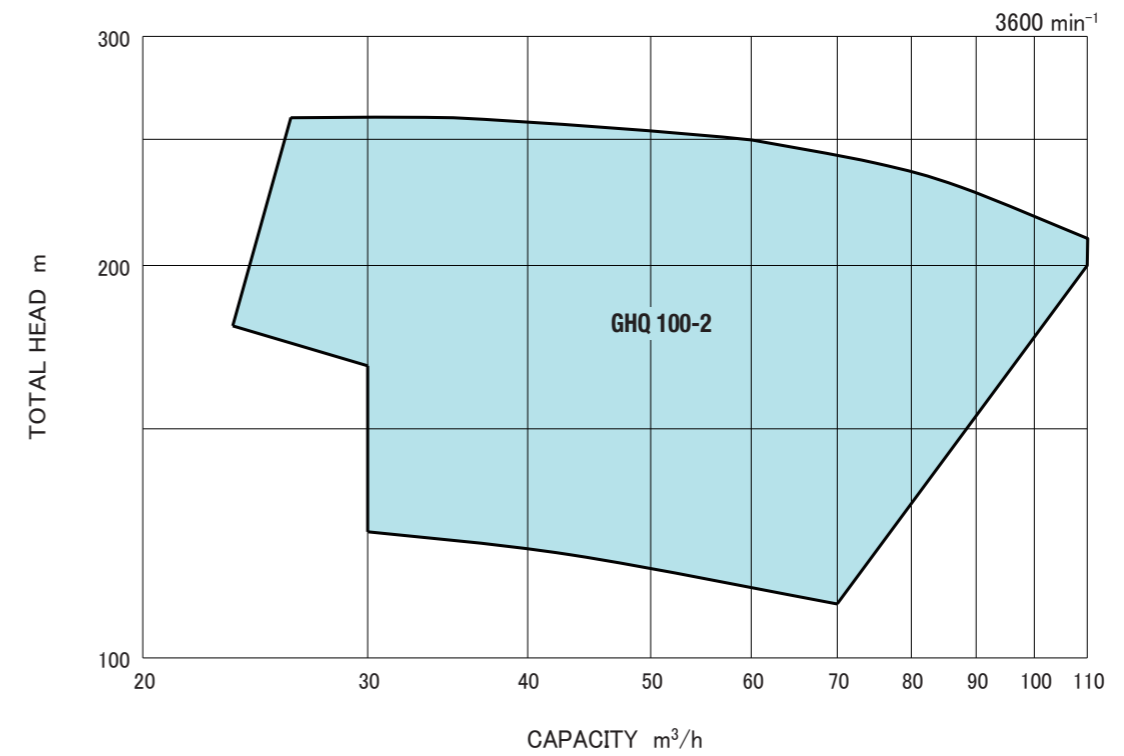

GHQ 100-2

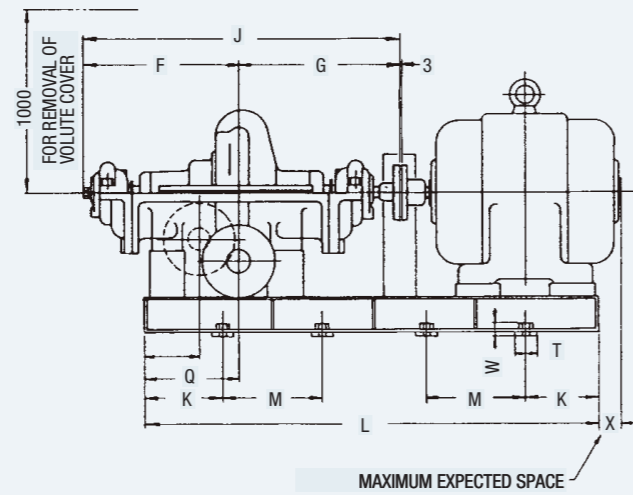
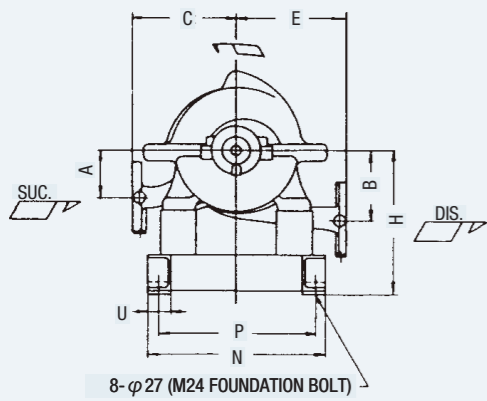

Dimensions:mm

Model	Motor(kW)	A	B	C	E	F	G	H	J	K	L	M	N	P	Q	R	T	U	W	X	Mecha. seal
GHQ 100-2	45 ≥										1340	380	430	370						133	50
	55~80	135	160	250	250	440	400	460	840	100	1430	410	560	500	290	140	110	75	25	133	
	90~110										1505	435	580	520						270	